

## Heavy Duty Compression Load Cell

### FEATURES

- Capacities 50–150 ton
- Ideal for multi-cell applications
- Compact, economical, column design
- Hermetically sealed to IP68
- 6-Wire (sense) circuit
- Stainless steel housing as standard

### APPLICATIONS

- Hopper and tank weighing
- Truck weighbridges

### DESCRIPTION

Model 122 is a heavy duty general purpose compression load cell particularly well suited for hopper and tank weighing and many other large scale industrial applications, including weighbridges for truck weighing.

The simple, compact column design and rugged hermetically sealed construction of the Model 122 load cell assures its long-term life in all types of field installations.



**ATEX**

The Model 122 load cell is often used in multi-cell installations, therefore its standard output tolerance is within 0.1%.

The two additional sense wires feed back the voltage reaching the load cell. Complete compensation of changes in lead resistance due to temperature change and/or cable extension, is achieved by feeding this voltage into the appropriate electronics.

### OUTLINE DIMENSIONS in millimeters

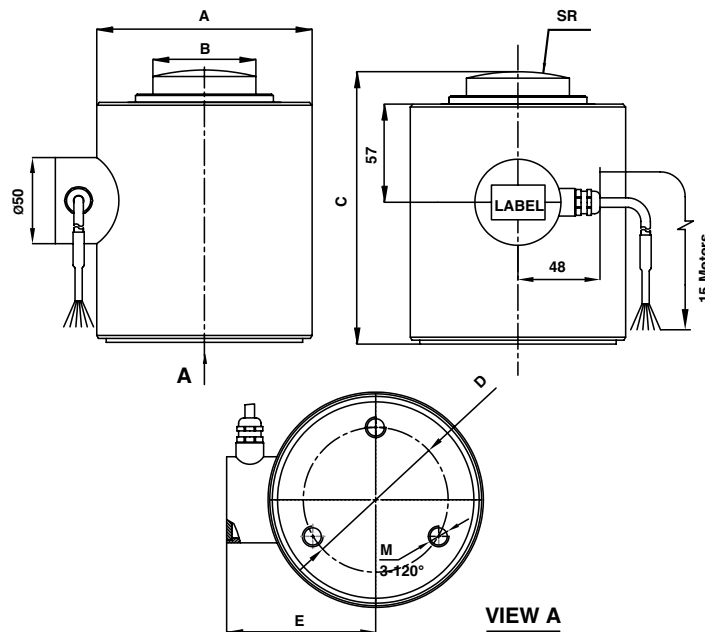

CAPACITY	A	B	C	D	E	M	SR
50T	Ø88	Ø45	122	Ø50	69	M10	SR35
100T, 150T	Ø125	Ø59.8	158	Ø84	86.5	M12	SR120

## Heavy Duty Compression Load Cell

SPECIFICATIONS				
PARAMETER	VALUE			UNIT
Rated capacity – R.C. ( $E_{max}$ )	50	100	150	ton
NTEP/OIML accuracy class	Non-Approved <sup>(1)</sup>			
Maximum no. of intervals (n)	2000			
$Y = E_{max}/V_{min}$	2000			
Rated output – R.O.	1.5		2	mV/V
Rated output tolerance	0.0015			±mV/V
Zero balance	0.015		0.02	±mV/V
Zero return, 30 min.	0.030			±% of applied load
Total error (per OIML R60)	0.030			±% of rated output
Temperature effect on zero	0.03			±% of rated output/°C
Temperature effect on output, unbalanced	0.0080 <sup>(2)</sup>			±% of load/°C
Temperature range, compensated	5 to +45			°C
Temperature range, safe	-20 to +60			°C
Maximum safe central overload	150			% of R.C.
Ultimate central overload	200			% of R.C.
Excitation, recommended	10			VDC or VAC RMS
Excitation, maximum	15			VDC or VAC RMS
Input impedance	670±15	1270±20	1350±30	Ω
Output impedance	600±5	1205±5	1205±5	Ω
Insulation resistance	>2000			MΩ
Cable length	15			m
Cable type	6 wire, braided, PVC, single floating screen			Standard
Construction	Stainless steel housing, plated alloy steel sensor			
Environmental protection	IP68			

<sup>(1)</sup> Typical 80% utilization

<sup>(2)</sup> Balanced span compensation is available upon request

All specifications subject to change without notice.

**WIRING SCHEMATIC DIAGRAM**  
(Unbalanced bridge configuration)

