

Stainless Steel, Single-Column Compression Load Cell

FEATURES

- Rated capacities of 50,000 to 100,000 pounds; 25 to 50 metric tons
- Stainless steel, welded seal construction
- 30 feet standard cable length
- Trade certified for NTEP Class III: 10000 divisions and OIML R60 3000 divisions
- Welded *Sensorgage*™ sealed to IP67 standards
- Factory Mutual System Approved for Classes I, II, III; Divisions 1 and 2; Groups A through G. Also, non-incendive ratings (No barriers!)
- **Optional**
 - Fully hermetically sealed available to IP66/68 standards



APPLICATIONS

- Truck scales
- Tank, bin, and hopper weighing

IP67 welded seal comes standard with optional true hermetic IP68 sealing available upon request. This load cell is used primarily in truck and train scales, but can just as easily be used to weigh tanks and silos.

DESCRIPTION

The 65114 is a high capacity, stainless steel single-column compression load cell.

This product is specifically designed for use in rugged outdoor environments. Stainless steel construction with

This load cell is rated intrinsically safe by the Factory Mutual System (FM); making it suitable for use in potentially explosive environments. This load cell is certified for Legal-for-Trade applications by both American NTEP and International OIML standards.

OUTLINE DIMENSIONS in inches [millimeters]

Wiring

+ Excitation	Red
- Excitation	Black
+ Output	Green
- Output	White

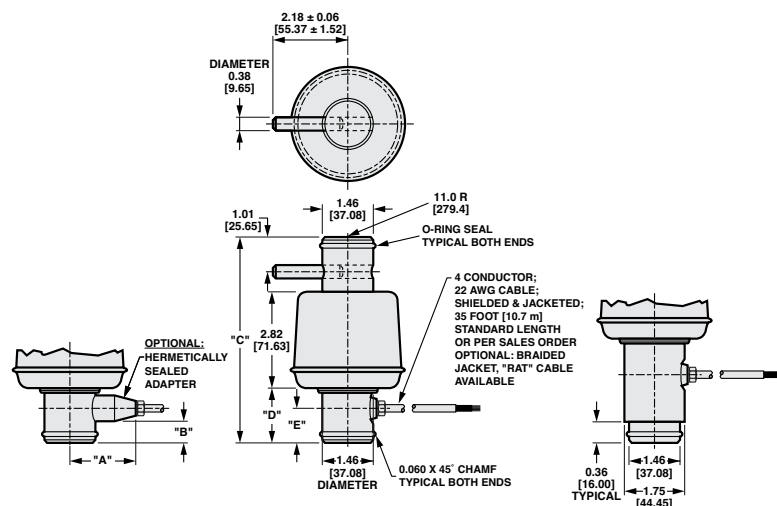

CAPACITY	A	B	C	D	E
50k	1.91	0.62	6.00	1.59	1.00
100k	2.08	2.01	8.86	3.04	2.01
25T	[48.51]	[15.75]	[152.40]	[40.39]	[25.40]
35T-50T	[52.83]	[51.05]	[225.04]	[77.22]	[51.05]

Capacities are in pounds [kg/T].

Stainless Steel, Single-Column Compression Load Cell

SPECIFICATIONS				
PARAMETER	VALUE			UNIT
Rated capacity—R.C. (E_{max})	50k, 100k 25, 35, 50			lbs tons
NTEP/OIML accuracy class	NTEP IIIIL	Standard	OIML R60	
Maximum no. of intervals (n)	10000 multiple		3000	
$Y = E_{max}/V_{min}$	NTEP cert. 97-081		8333	Maximum available
Rated output—R.O.	2.0			mV/V
Rated output tolerance	0.25			±% mV/V
Zero balance	1.0			±% FSO
Combined error	0.02	0.03	0.02	±% FSO
Non-repeatability	0.010	0.015	0.010	±% FSO
Creep error (30 minutes)	0.03	0.05	0.017	±% FSO
Temperature effect on zero	0.0010	0.0015	0.0010	±% FSO/°F
Temperature effect on output	0.0008	0.0008	0.0007	±% of load/°F
Compensated temperature range	14 to 104 (–10 to 40)			°F (°C)
Operating temperature range	0 to 150 (–18 to 65)			°F (°C)
Storage temperature range	–60 to 185 (–50 to 85)			°F (°C)
Maximum safe central overload	150			% of R.C.
Ultimate central overload	300			% of R.C.
Excitation, recommended	5–20			VDC or VAC RMS
Excitation, maximum	25			VDC or VAC RMS
Input impedance	1000 nominal			Ω
Output impedance	990–1010			Ω
Insulation resistance at 50 VDC	>1000			MΩ
Material	Stainless steel			
Environmental protection	IP67*			

* Hermetically sealed to IP68 upon request

FSO—Full Scale Output

All specifications subject to change without notice.