

Compression Load Cell



FEATURES

- Capacities: 50 to 200Klbs
- Certified to NTEP class III, 10000 divisions
- Environmental protection: IP68 (DIN 40.050)
- Material: Stainless Steel
- Hermetically sealed - IP68

OPTIONAL FEATURE

- FM approved for use in potentially explosive atmosphere

DESCRIPTION

The 792 canister is designed for compression applications. Its stainless steel construction combined with hermetically sealing allows the 792 to be used in harsh environments.

Built for heavy capacity weighing applications where accuracy and reliability are required over long periods of time.

Hermetic sealing offers excellent protection from moisture and provides longterm stability and reliability.

APPLICATIONS

- Silo, tanks and hoppers
- Suspended silos, tanks and hoppers
- Railroad scales
- Weighbridges

OUTLINE DIMENSIONS in inches

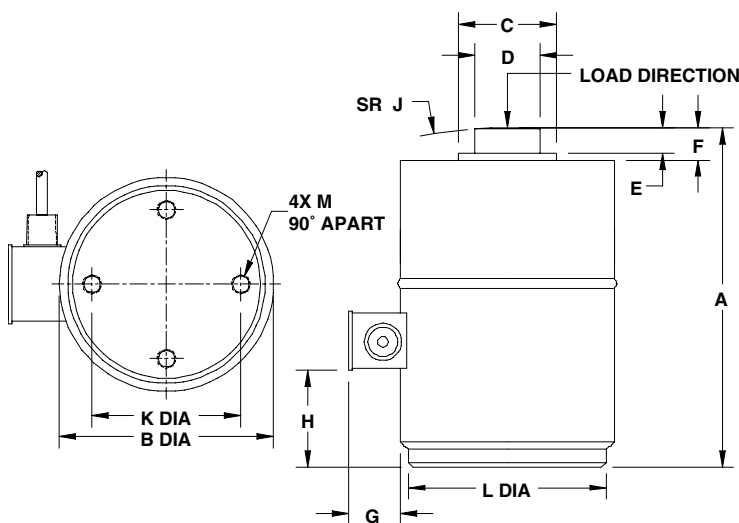

Cable specifications:

Cable length: 10.7m (35ft)

Excitation + Green

Excitation - Black

Output + White

Output - Red

Shield Transparent

Cable screen is not connected to load cell body

Capacity	50	100	200
A	7.50	9.13	11.63
B	4.50	5.75	7.50
C	1.77	2.65	3.15
D	1.25	1.75	2.50
E	0.58	0.88	0.80
F	0.75	1.05	0.97
G	1.25	1.40	1.34
H	1.12	1.33	2.53
J	6.00	12.00	12.00
ØK	2.38	4.00	5.50
L	4.18	5.31	6.81
ØM	3/8-24 UNF-2B	1/2-20 UNF-2B	5/8-18 UNF-2B

SPECIFICATIONS

PARAMETER	VALUE		UNIT
Standard capacities (E_{max})	50, 100, 200		Klbs
Metric equivalents	22.7, 45.4, 91		t
Accuracy class according to NTEP	NTEP IIIIL	Non-Approved	
Maximum no. of verification intervals (n)	10000		
Rated output (=S)	2		mV/V
Rated output tolerance	0.002		±mV/V
Zero balance	10.0		±% FSO
Combined error	0.0200	0.1000	±% FSO
Non-repeatability	0.0100	0.0200	±% FSO
Creep error (20 minutes)	0.0300	0.0500	±% applied load
Temperature effect on minimum dead load output	0.0009 (0.0010)	0.0140	±% FSO/5°C (°F)
Temperature effect on sensitivity	0.0072 (0.008)	0.0070	±% applied load/5°C (°F)
Maximum safe over load	150		% E_{max}
Ultimate over load	300		% E_{max}
Maximum safe side load	10		% E_{max}
Minimum dead load	1000		lbs
Excitation voltage	10		V
Maximum excitation voltage	15		V
Input resistance	350±3.5		Ω
Output resistance	350±3.5		Ω
Insulation resistance	≥5000		MΩ
Compensated temperature range	-10 to +40 (+14 to +104)		°C (°F)
Operating temperature range	-40 to +80 (-65 to +200)		°C (°F)
Element material (DIN)	Stainless steel		
Sealing (DIN 40.050 / EN60.529)	IP68		

FSO-Full Scale Output

Note: Correct mounting of the load cells is essential to ensure optimum accuracy and performance. Further information is available upon request.