

Type CR Load Cell



Features 主要特点

- Multi-column load cell
- Senior aluminum (≤500kg)
- Senior alloy steel (1t~5t)
- Easy to install
- High accuracy
- High stability
- Suitable for testing machine, etc.

- 柱式传感器
- 优质铝合金材质 (≤500kg)
- 优质合金钢材质 (1t~5t)
- 安装简便、快速
- 高精度
- 高稳定性
- 适用于材料实验机等

Schematic 接线方式

- | | | | |
|---------|----------|------|------|
| Red : | + input | 红色 : | + 激励 |
| Black : | - input | 黑色 : | - 激励 |
| Green : | + output | 绿色 : | + 信号 |
| White : | - output | 白色 : | - 信号 |

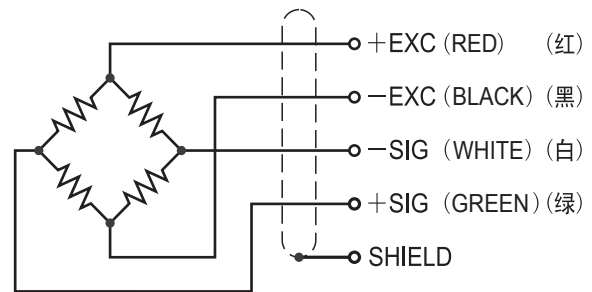

Capacities 量程

5kg, 10kg, 20kg, 50kg, 100kg, 200kg, 250kg, 500kg,
1t, 2t, 3t, 5t

Dimensions 尺寸

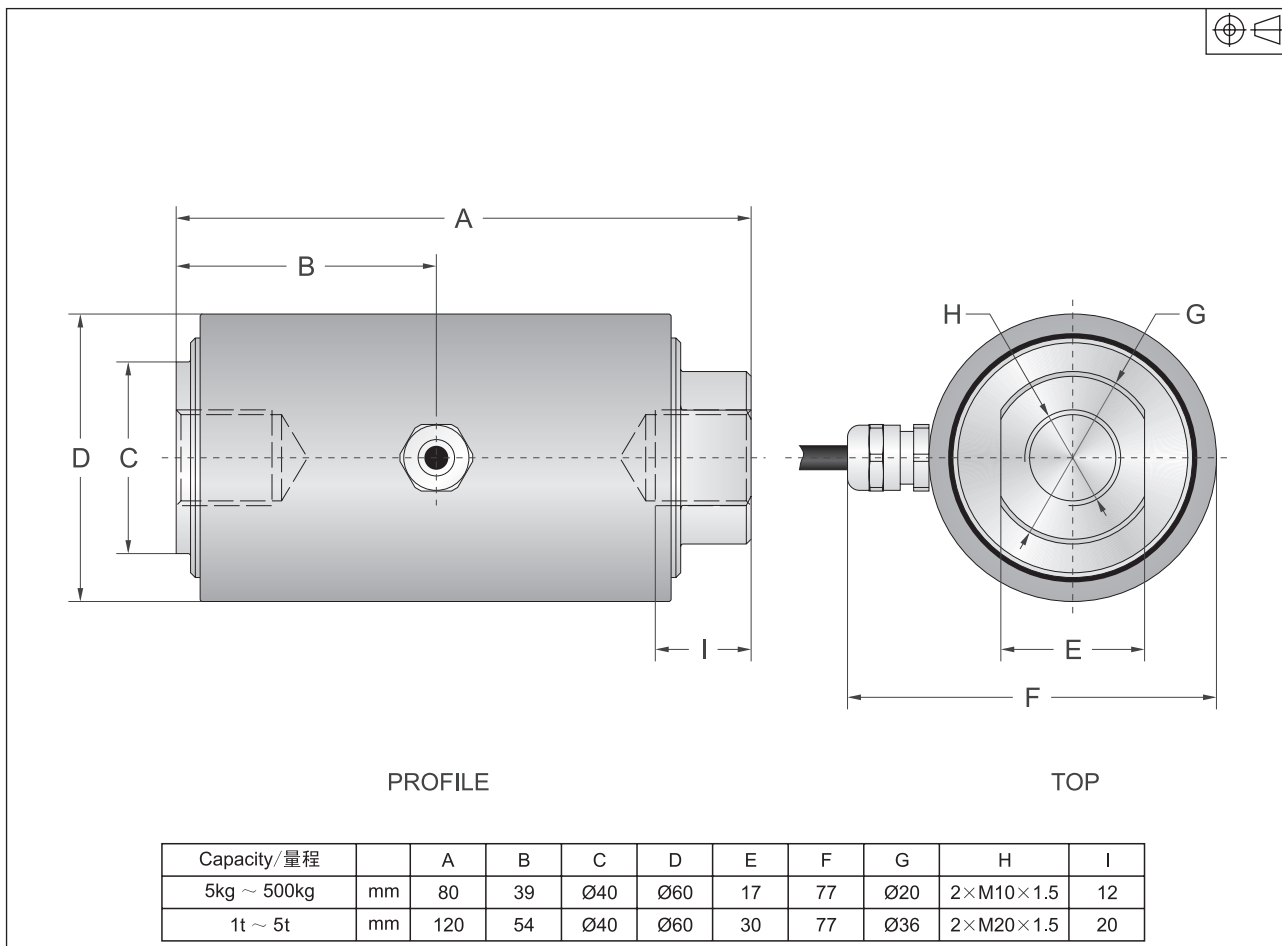

Specification 技术参数

Rated Output	额定输出	2.0mV/V ±2.5%
Zero Balance	零点平衡	±3%(≤100kg) / 1%(200kg~5t) of rated output
Creep after 30 minutes	蠕变	±0.03% of rated output
Nonlinearity	非线性	±0.03% of rated output
Hysteresis	滞后	±0.03% of rated output
Repeatability	重复性	±0.03% of rated output
Temp. effect on output	灵敏度温漂	≤0.002% of applied output/°C
Temp. effect on zero	零点温漂	≤0.002% of rated output/°C
Safe Temp. Range	可用温度范围	-10°C to + 70°C
Temp. Compensated	温度补偿范围	-10°C to + 40°C
Safe Overload	安全载荷	150%
Input Impedance	输入阻抗	387 ohm ± 50 ohm
Output Impedance	输出阻抗	350 ohm ± 5 ohm
Insulation Resistance	绝缘阻抗	≥5000 M ohm (50V DC)
Rated Excitation	推荐激励电压	10V DC/AC
Maximum Excitation	最大激励电压	15V DC/AC
Cable Length	导线长度	2.75m
Cable Color Code	导线颜色	Red(+ E) Black(- E) Green(+ S) White(- S)

Column Type