

## Multi-Column Compression Load Cell

### FEATURES

- Capacity range: 10T–100T
- Low profile
- 4-Column design ensures low sensitivity to eccentric loads
- Hermetically sealed to IP68
- Full stainless steel welded construction for washdown and harsh environments
- OIML approved to 3500d (OIML R-60)
- Easy corner calibration with current matched (mV/V)/ohm output
- Current calibration output (SC version) ensures easy and accurate parallel connection of multiple load cells
- **Optional**
  - $V_{min}$  approval limit:  $y = E_{max}/V_{min} = 23,333$



### APPLICATIONS

- Truck weighbridges
- Silo and hopper weighing
- Train “rail” scales
- Process weighing

### DESCRIPTION

The Model CSP is a multi-column compression load cell.

Full stainless steel hermetically sealed construction to IP68 ensures reliable performance in harsh, washdown areas.

The proven, four column design provides high accuracy and low sensitivity to eccentric loads.

Output calibration by current matching (mV/V)/ohm eliminates time consuming corner calibration procedures in multicell applications.

Transducers CSP load cells are directly interchangeable with existing Revere CSP-M cells.

OIML C3.5 (3500 divisions) approval is standard.

### OUTLINE DIMENSIONS in millimeters

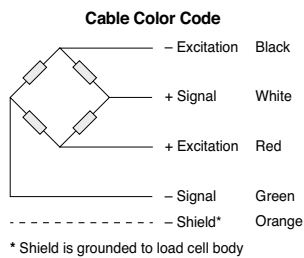

Optional mounting kit—  
consult Sales Office

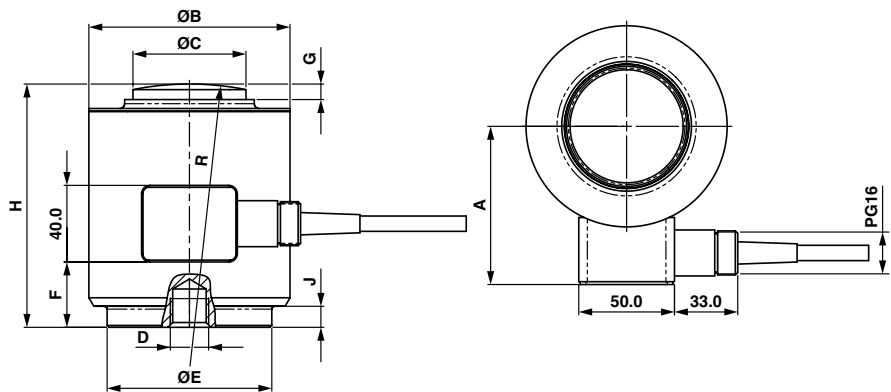
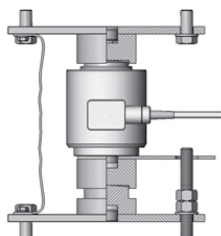

Capacity	A	B	C	D	E	F	G	H	J	R
10–25T	63	72	32	M12 x 8 Deep	57	13	7	83	2	150
40–60T	83	105	59	M20 x 15 Deep	86	35	8	127	11	150
100T	107	150	80	M20 x 15 Deep	124	70	22	185	20	430

## Multi-Column Compression Load Cell

SPECIFICATIONS				
PARAMETER	VALUE			UNIT
Rated capacity—R.C. ( $E_{max}$ )	10000, 25000, 40000, 60000, 100000			kg
NTEP/OIML Accuracy class	C1/20 (ref.)	C3/30	C3.5/30	
Maximum no. of intervals (n)	1000 (ref.)	3000	3500	
$Y = E_{max} / V_{min} *$	5000	10000	11667	
Rated output—R.C.	2.0			±mV/V
Rated output tolerance	0.02			±mV/V
Zero balance	0.02			±mV/V
U/R ratio error	0.05			±%
Nominal U/R ratio	0.00417			(mV/V) / Ω
Total Error	0.030	0.020	0.018	±% of R.O.
Creep (30 minutes)	0.070	0.023	0.020	±% of load
Zero return (30 minutes)	0.050	0.017	0.014	±% of load
Temperature effect on output	0.003	0.0012	0.001	±% of load/°C
Temperature effect on zero	0.0028	0.0014	0.0012	±% of R.O./°C
Temperature range, compensated	-10 to +40			±% applied load/5
Temperature range, safe	-40 to +80			% $E_{max}$
Temperature range, storage	-40 to +90			% $E_{max}$
Maximum safe static overload	150			% $E_{max}$
Ultimate static overload	400			% $E_{max}$
Maximum safe side load	10			mm
Excitation, recommended	10			V
Excitation, range	5–40			V
Input impedance	450±4.5			Ω
Output impedance	480±4.8			Ω
Insulation resistance	>2000			MΩ
Cable length	10000 kg	10		°C
	All other capacities	20		°C
Cable type	4 conductors, (AWG 20) PVC jacket grounded shield			°C
Construction	Stainless steel, welded seal			
Environmental protection (per DIN 40050)	Hermetically sealed, IP68			

\* Approval limit,  $Y = 23333$

\*\* Available approval for use in potentially explosive atmospheres: II 2G EEx ia IIC T4

All specifications subject to change without notice.