

Load Cell for Rotary Filling Machines

FEATURES

- The first and only load cell specifically designed for use in rotary filling machines
- Short settling times
- High resistance to side loads
- Effective isolation of base vibrations
- Centrifugal forces do not affect accuracy
- Two mounting options

APPLICATIONS

- Rotary filling machines

DESCRIPTION

Model 1410 represents a radical new concept in load cell design, which alleviates many of the problems encountered when conventional load cells are used in rotary weighing machines.

Due to a patented damping system, typical settling times of 700 ms are dramatically reduced to less than 300 ms (depending upon conditions), significantly reducing cycle times and increasing throughput capabilities.

Centrifugal forces are handled in such away that their effect on output is very small. For example, tested up to 20 rpm, total dynamic error amounted to less than

0.2 gram per kg. Also the Model 1410 provides excellent isolation of base vibrations. Both features enable use of higher machine speeds without loss of accuracy.

The uniquely rugged construction of the Model 1410 is very resistant to side loads and can therefore withstand bottle jams and other mishaps.

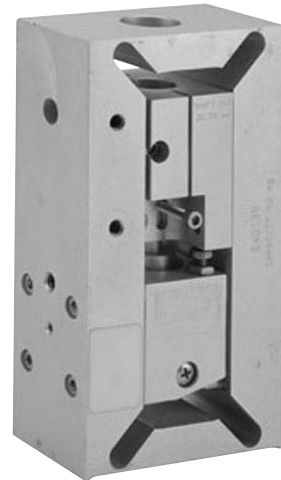

OUTLINE DIMENSIONS in millimeters

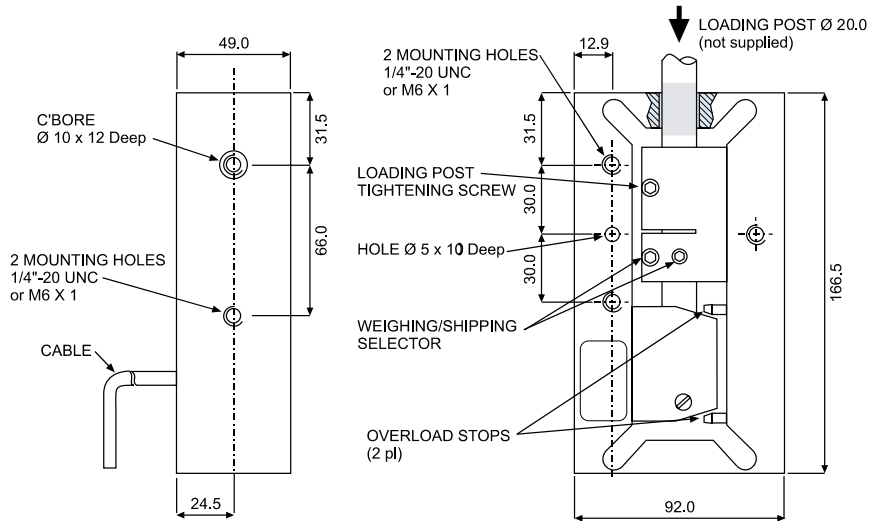

For different mounting configuration consult factory.

Load Cell for Rotary Filling Machines

SPECIFICATIONS			
PARAMETER	VALUE		UNIT
Rated capacity—R.C. (E_{max})	10, 20, 30		kg
T-H accuracy class	E	G	
Rated output—R.O.	2		mV/V
Rated output tolerance	0.3		±% mV/V
Zero balance	-0.0 / +0.2		±% mV/V
Total static error at room temperature per OIML	0.05	0.02	±% of R.O.
Dynamic error: speed range of 0 to 15 rpm, rotational radius of 1m, load placed on platform located 14 cm above top surface of load cell and connected by 3/4" or 20 mm dia. steel shaft	0.04		±% of the static reading at same load
Creep and zero return (30 min.)	0.05	0.025	±% of load
Temperature effect on zero	0.010	0.004	±% of R.O./°C
Temperature effect on output	0.003	0.001	±% of load/°C
Temperature range, compensated	+5 to +40		°C
Temperature range, safe	-30 to +70		°C
Maximum safe static overload, positive	160 Factory adjusted to 120 ... 160% of R.C.		% of R.C.
Maximum safe static overload, negative	-120 Factory adjusted to -30 ... -120% of R.C.		% of R.C.
Ultimate static overload (central loading)	300		% of R.C.
Excitation, recommended	10		VDC or VAC RMS
Excitation, maximum	15		VDC or VAC RMS
Input impedance	415±15		Ω
Output impedance	350±3		Ω
Insulation resistance	>2000		MΩ
Cable length	0.6		m
Construction	Anodized aluminum		
Damping	Internal silicone fluid damping. Piston has two positions: working and shipping. In shipping position the cylinder is sealed.		

All specifications subject to change without notice.

WIRING SCHEMATIC DIAGRAM (Unbalanced bridge configuration)

